

2. Scattering and Diffraction

Scattering/Wave Terminology

A few terms show up throughout the discussion of electron microscopy:

First, what do we mean by the terms *elastic* and *inelastic*? These are both related to the collisions of particles, particularly in comparing the kinetic energy before and after the collision. If the total of the kinetic energy of all particles involved in the collision is unchanged, the collision is elastic. If not, it is inelastic. It is almost guaranteed, though, that if all of the particles move freely of each other before and after the collision, the number of particles doesn't change, and their identities don't change (e.g. two electrons in, two electrons out) that the collision is elastic. If the products of the collision are different than the entities fed into it, the collision will be inelastic.

The terms *coherent* and *incoherent* describe wave properties. They refer to the phase relationships (differences) among different waves (or different parts of the same wave, if you will.) Coherent indicates that there is a constant and well-defined phase relationship. Incoherent means there is no distinct phase relationship, i.e., the phase difference is random.

The above terms are often related to the scattering angle, such as for a less massive particle, like an electron, scattering off of a more massive target, like an atom, which is usually assumed to be initially at rest. The scattering angle describes the change of direction, that is the angle between the initial and final directions of propagation. If this angle is less than 90° *forward* scattering occurred. Greater than 90° , *back* scattering occurred.

Coherent Scattering

We can say a bit more about coherent scattering of electrons, since we established that wavelength is a function of kinetic energy. First of all, we don't have to require that the initial and scattered parts of the wave have exactly the same phase (zero phase shift, in-phase), only that the relative phase shift caused by scattering is constant. But we do require that the scattering is elastic. If the scattering is inelastic, the energy of the electron after scattering will almost never equal its energy before scattering; usually it will be less, because some energy was transferred to the target atom. If the scattering is elastic, the energy is unchanged, so the momentum is unchanged, so the wavelength is unchanged, so the scattered wave is coherent. So we often say "coherent" scattering, when we really mean "elastic" scattering, because elastically scattered waves remain coherent with respect to the incident wave, whereas inelastically scattered waves are incoherent with respect to the incident wave.

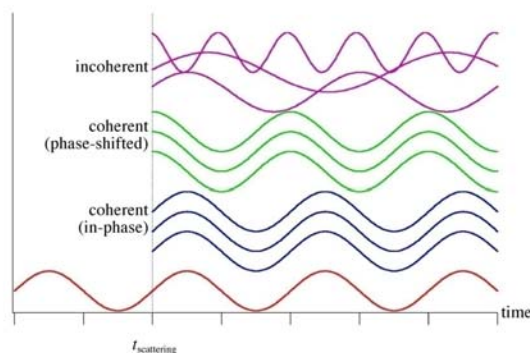

Coherent vs. Incoherent Solids

The terms coherent and incoherent do show up in other contexts involving materials characterization, though. For example, a solid with long-range order, which we call a crystal, is sometimes called a

coherent solid. A solid with no long-range order (though it almost certainly has short-range order, due to its atomic nature), also known as an amorphous solid, is sometimes called an incoherent solid. Even here, though, the origins of the terminology can be traced back to scattering experiments.

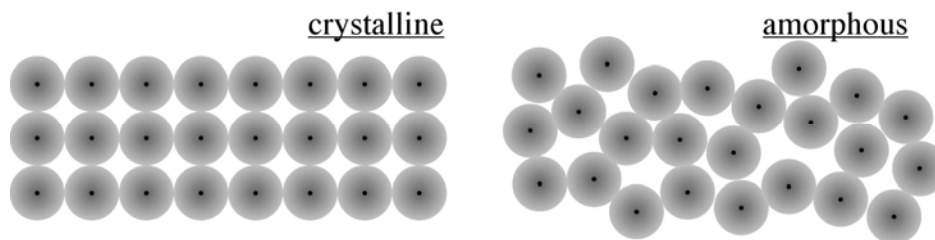

Scattering Cross-Section

If we are throwing darts at a dart board, the board has a certain target area. Smaller portions of the target, like the bulls-eye, are harder to hit, so they count for more points. We might go so far as to say that, after many, completely random throws at the dart board, the number of hits in a given area of the board is proportional to the size of the area.

In our discussion, this is analogous to directing a parallel beam of electrons at an atom. We could assume the atom is a hard sphere, so it has a circular cross-section when projected onto a plane normal to the beam direction. Now, even if the atom is not a sphere, its size as a target can be described by a cross-sectional area, called the scattering cross-section σ_0 . The units of scattering cross section are barns, where

$$1 \text{ b} = 10^{-24} \text{ cm}^2$$

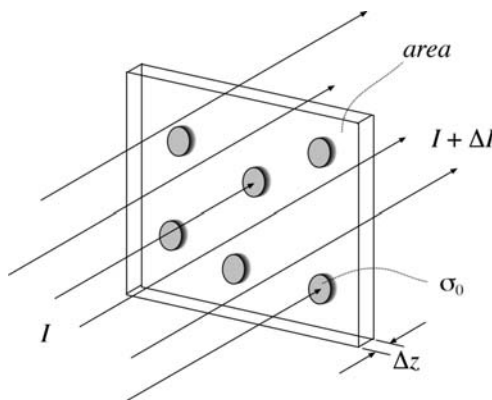

More realistically, we have a thin foil of material contain many scatterers (atoms). Let's say there are n scatters per unit volume. If our foil has thickness dz , the number of scatters is $N = n \cdot \text{area} \cdot \Delta z$. If the slice is *very* thin, the fraction of the beam scattered is then $N \cdot \sigma_0 / \text{area} = n \cdot \sigma_0 \cdot \Delta z$. In other words, the intensity decreases by

$$dI = -n \cdot \sigma_0 \cdot I \cdot dz$$

Mean Free Path

We can write a differential equation with separated variables:

$$\frac{dI}{I} = -\mu \cdot dz$$

Instrumentation for Characterization of Nanomaterials (v12)

The attenuation constant is $\mu = n \cdot \sigma_0$

If the material contains only a single element:

$$n = \frac{N_A \cdot \rho}{M}$$

where N_A is Avogadro's number, ρ is the mass density, and M is the molar atomic mass. Now

$$\mu = \frac{N_A \cdot \rho \cdot \sigma_0}{M}$$

Integrating over the foil thickness T :

$$\int_{I'=I_0}^{I'} \frac{dI'}{I'} = -\mu \cdot \int_{z=0}^T dz$$

This gives a decaying exponential

$$I(T) = I_0 \cdot e^{-\mu T}$$

The mean free path is a characteristic length for scattering

$$\Lambda = \frac{1}{\mu}$$

Interpreting Cross-Section

Scattering cross-sections are linked to the probability of scattering off some particular type of scattering center, such as atoms. The scattering may be a physical area of the target times a probability for scattering. So a target with physical area a and probability for scattering $P=1$ would have the same scattering cross section as a target with area $4a$ and probability for scattering $P=0.25$. In both cases, $\sigma = 1 \cdot a = (0.25) \cdot (4a) = a$.

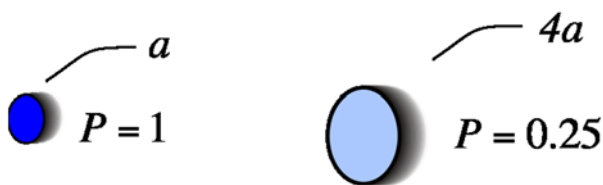

Units: Solid Angle

In 2-D, angles map onto arc segments of a circle. In 3-D, we use solid angles that map onto the surface of a sphere. A solid angle Ω is defined given by the area of the surface area of the enclosing sphere it subtends, divided by the radius-squared of the sphere, and expressed in units of steradians (sr):

$$\Omega = \frac{\Delta A}{r^2}$$

The surface area of a sphere is $4\pi r^2$, so $0 \leq \Omega \leq 4\pi$ sr. In some contexts, the conversion is made $1 \text{ sq. deg.} = (\pi/180)^2 \text{ sr}$, but we won't use that in this class. **Use sr!**

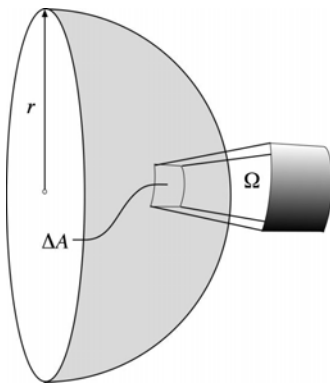

Solid angle has several uses in our discussion, such as when we wish to resolve the cross-section for scattering into different directions.

Scattering from Single Slit (Narrow)

Huygens' Principle provides a useful insight into wave propagation: *Every point on a wave front acts as a source of secondary, spherical "wavelets"*. When picturing a plane wave - one that moves uniformly in one direction, extending everywhere in space - we often draw parallel lines, called "wave fronts", evenly spaced by the wavelength λ . Here we take these to represent the maxima of a real-valued wave function (though, in fact, the intensity has half of this wavelength spacing.)

Huygens says that there is a spherical wave (which we picture as a circle in 2-D) radiating outward from every point on these parallel lines. With a little thought, this can be seen to result in the propagation of the wave in the direction normal to the wave fronts, as we would expect for a plane wave. For a full description, it is important to know that the amplitude of the wavelets is largest in the forward direction and vanishes in the backward direction. But, we will be mainly concerned with forward scattering in the discussion of TEM, so this amplitude (obliquity) factor is not important now.

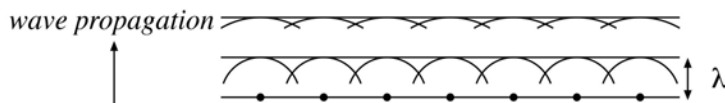

We just use wavelets to explain something we already knew: that plane waves propagate in one direction with parallel wave fronts. But now imagine the plane wave incident on a screen with a very small aperture, or slit. (We will talk about a slit running out of the page for now, which is easier to draw and analyze.) The slit is so small, it selects out only one wavelet from each wave front. So on the back side of the screen, a spherical wave emerges. This is the result of scattering off of a single, narrow slit. The deviation of the plane wave from its initial, straight-line path is called *diffraction*.

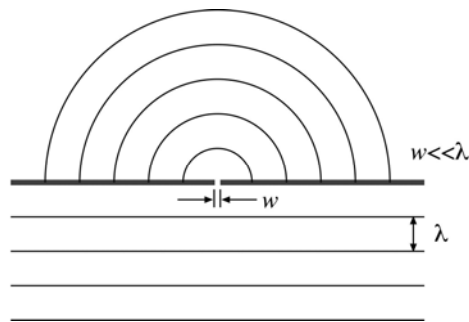

Two Slit Interference Pattern (Narrow)

A screen with two, narrow, parallel slits will produce two spherical waves. Since these originate from the same incident wave, they will be coherent with one another, meaning we must add their amplitudes, rather than their intensities. (More on this in Ch. 3). The resulting intensity at any point on the back of the screen will depend on the path length difference to that point from each of the slits. Far from the screen, this is called the far-field, or Fraunhofer, diffraction pattern.

Specifically, if the slits are separated by a distance d , the intensity at some angle θ from the initial propagation direction is approximately:

$$I(\theta) = I_0 \cdot \cos^2\left(\frac{\pi \cdot d \cdot \sin \theta}{\lambda}\right)$$

Essentially, the two slits are coherent sources, and the resulting intensity is their interference pattern. (There is a nice java applet for this: <http://www.phy.ntnu.edu.tw/ntnujava/index.php?topic=15>)

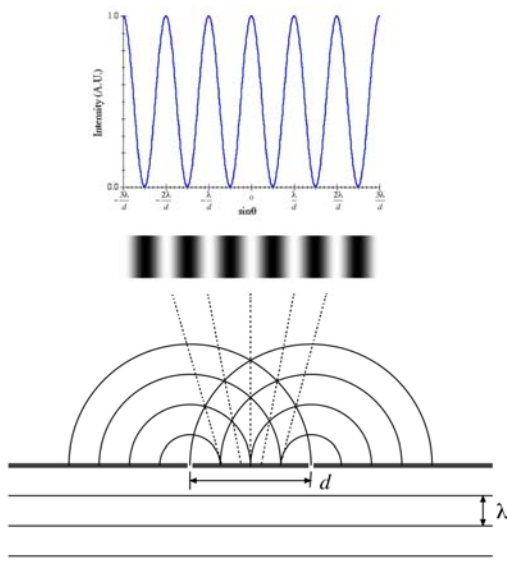

Single-Slit Diffraction

We had assumed that each slit was very narrow, much smaller than the wavelength. Let's call the slit-width w , where $w \ll \lambda$. As w gets a little bigger, more wavelets are allowed through each slit, and the scattered wave is no longer perfectly spherical (or circular, in 2-D). With a single slit of finite width, the diffracted intensity has the form:

$$I(\theta) = I_0 \cdot \text{sinc}^2\left(\frac{\pi \cdot w \cdot \sin \theta}{\lambda}\right), \text{ where } \text{sinc}(x) \equiv \frac{\sin x}{x}$$

Instrumentation for Characterization of Nanomaterials (v12)

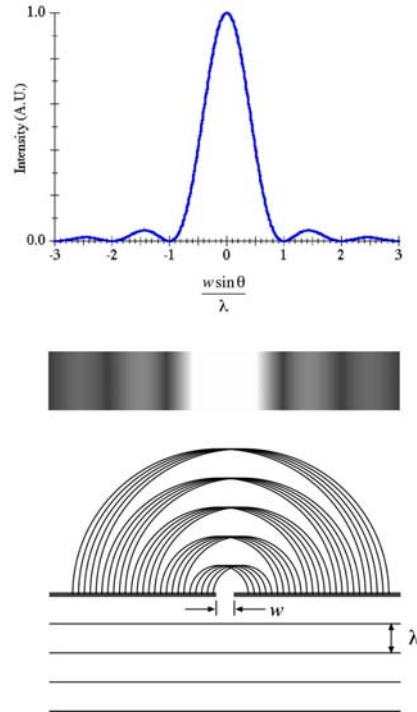

This gives a bright central maximum, with intensity fringes on either side, which drop off in intensity as the angle increases. Notice that if $\lambda \ll w$, most of the intensity occurs at small angles, where $\sin\theta \approx \theta$.

Two-Slit Superposition

We now consider two closely spaced, incoherent sources, separated by a distance δ , but with the same wavelength λ . In reality, this implies some other imperfections in the sources, so there must be other wavelengths present, but we ignore that for now. We want to project onto a screen the diffraction patterns from these two sources generated by a single slit of width w at a very large distance L from the sources. The semi-angle of collection β refers to half the angular width of the slit when viewed from the sources. The semi-angle between the sources ϕ is half the angular separation of the sources when viewed from the slit. The distance is large, so the angles must be small:

$$\beta \approx \frac{w}{2L}, \quad \phi \approx \frac{\delta}{2L}$$

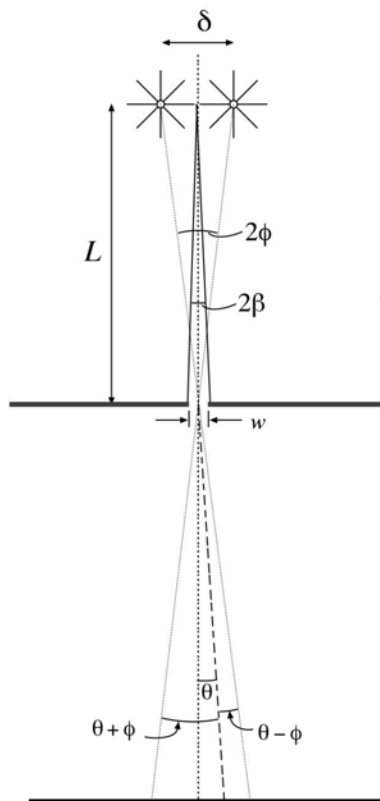

Since we are ignoring interference, we just add the intensities of the two separate diffraction patterns.

$$I(\theta) = I_0 \cdot \text{sinc}^2 \left[\frac{\pi \cdot w \cdot (\theta - \phi)}{\lambda} \right] + I_0 \cdot \text{sinc}^2 \left[\frac{\pi \cdot w \cdot (\theta + \phi)}{\lambda} \right]$$

Rayleigh Criterion

Rayleigh came up with a rule-of-thumb for resolution: The two sources (objects) are just resolvable if the central maximum from one falls outside the first minimum of the other.

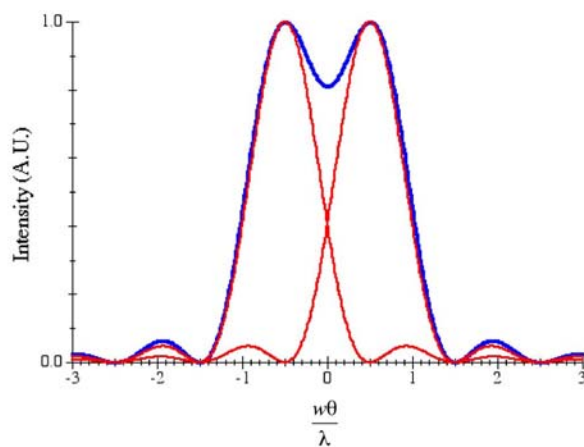

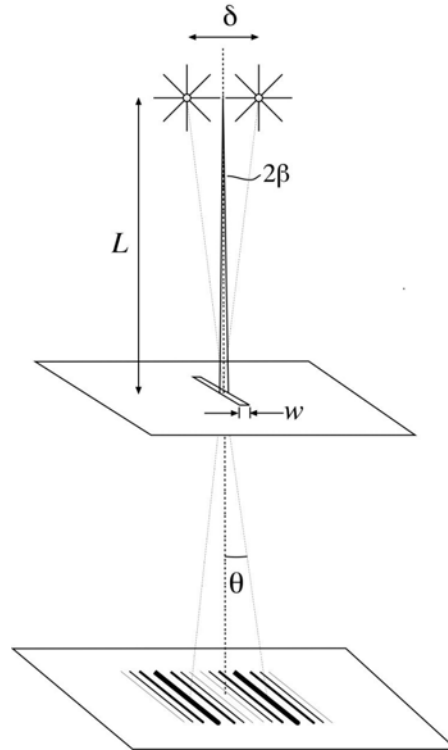

Resolution: Rayleigh Criterion for Slits

We can apply this criterion to our two-slit superposition intensity. The angle θ_0 of the maximum for source 1 must satisfy:

$$\text{sinc}^2 \left[\frac{\pi w (\theta_0 - \phi_{\min})}{\lambda} \right] = 1$$

If θ_0 is also a minimum for source 2:

$$\text{sinc}^2 \left[\frac{\pi w (\theta_0 + \phi_{\min})}{\lambda} \right] = 0$$

Using the central maximum of 1 and the first minimum of 2, we find:

$$\frac{w(\theta_0 - \phi_{\min})}{\lambda} = 0 \quad \text{and} \quad \frac{w(\theta_0 + \phi_{\min})}{\lambda} = 1$$

So we can find the minimum angular separation for resolution:

$$\frac{2w\phi_{\min}}{\lambda} = 1 \Rightarrow \phi_{\min} = \frac{\lambda}{2w}$$

The minimum spatial separation is:

$$\phi_{\min} = \frac{\delta_{\min}}{2L} \Rightarrow \delta_{\min} = \frac{L\lambda}{w}$$

In terms of angles:

$$\delta_{\min} = \frac{\lambda}{2\beta} = (0.5) \frac{\lambda}{\beta}$$



The result for circular apertures (rather than slits) is more common and widely applicable:

$$\delta_{\min} = (0.61) \frac{\lambda}{\beta}$$

Modified Resolution Threshold for Slits

Taking the premise a step further, for the sake of conversation, we could define the resolution threshold based on the minimum separation at which an intensity minimum appears in the projected pattern. We would need to solve for the minimum separation for which the curvature of $I(\theta)$ at $\theta=0$ is zero. This can be done computationally, with the result for slits:

$$\delta_{\min}^* = (0.41) \frac{\lambda}{\beta}$$

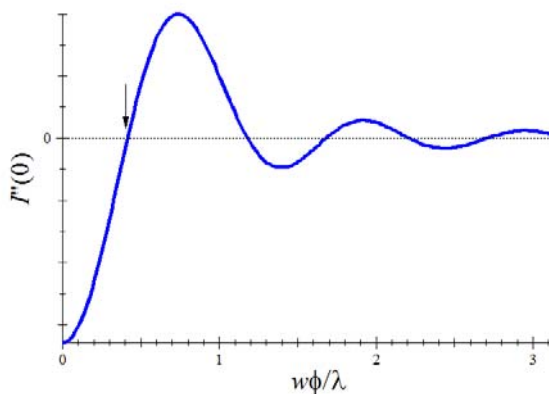

Notice that this criterion gives slightly better resolution (smaller δ_{\min}) than the Rayleigh criterion.

Two-Slit Interference with Diffraction

To estimate resolution, we assumed the sources were incoherent. If, in fact, they are coherent, we will have interference between the slits, giving the intensity profile:

$$I(\theta) = I_0 \cdot \cos^2\left(\frac{\pi \cdot d \cdot \sin \theta}{\lambda}\right) \cdot \text{sinc}^2\left(\frac{\pi \cdot w \cdot \sin \theta}{\lambda}\right)$$

Now there are two oscillations present. (We can assume $w < d$). A low-frequency oscillation corresponding to the sinc^2 function results from the slit width. A higher frequency \cos^2 oscillation results from the interference.

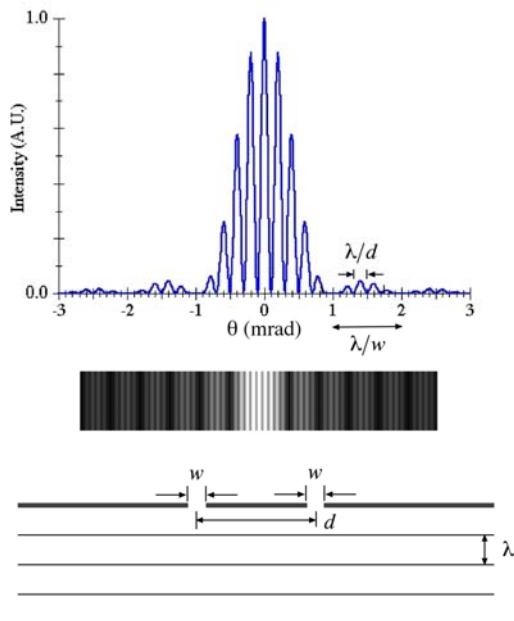

Beam/Imaging Angle

We have already seen how various angles affect the scattered intensity. We will try to stick with certain definitions:

α : beam-convergence semi-angle

β : collection semi-angle

θ : scattering angle

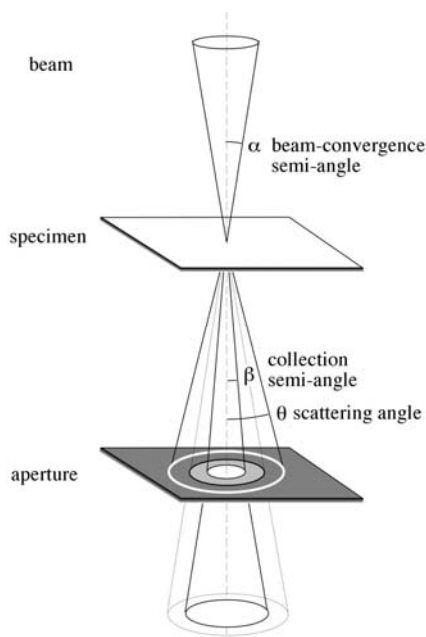

The angle of beam convergence is especially important when we are trying to illuminate an area on the specimen with a small probe. The angle for collection is adjusted with apertures or detectors to control the type and amount of image contrast, and has major influence on resolution (as we have seen). This is a

consequence of the various influences on scattering into different ranges of scattering angle. The scattered signal will contain different information depending on which portion of the signal is detected.

Electron Diffraction Patterns

In this course, we will most often discuss diffraction patterns as 2-D distribution of scattered intensity observed far from the sample (Fraunhofer diffraction). There are many variants of the basic electron diffraction methods, but most will analyze will be either 1) selected-area electron diffraction patterns, or 2) convergent-beam electron diffraction patterns. Selected-area diffraction uses a nearly parallel electron beam. Patterns from single crystals show strong, sharp spots, corresponding to long-range order. These are actually intensity peaks, but tend to look like white circles, because the tops of the peaks are clipped when adjusting the image brightness/contrast. Polycrystalline materials show many fainter, sharp spots, located within well-defined rings. The spots form continuous rings as the crystallite size gets smaller and the number of crystals contributing gets bigger. Amorphous materials give rise to diffuse rings, which indicate the presence of short-range order.

The main feature of convergent-beam patterns from single crystals is diffraction disks, rather than spots. The disks usually contain many intensity oscillations and extra features, which can be described by dynamical diffraction theory. Compared to selected-area patterns, these patterns are generated from very small sample volumes. Convergent-beam patterns from small crystals, such as nanoparticles, look similar to those from larger, single crystals, except the some of the dynamical information may be lost. Convergent-beam patterns from amorphous materials are not often used to study the materials themselves, but are often displayed as a way to align the microscope, since the material is assumed to be isotropic.

